

## Spin-On Filter Elements

### Description

STAUFF offers a wide range of Spin-On filter heads and Spin-On filter elements.

#### Sealing Material

- NBR (Buna-N®)

#### Media Compatibility

- Mineral oils, other fluids on request

#### Temperature Range

- -30 °C ... +100 °C / -22 °F ... +212 °F

#### Filter Materials

- Wire Mesh, Brass Mesh, Filter Paper, Inorganic Glass Fibre, Stainless Wire Mesh and Water Absorbing Filter Material

### Options and Accessories

#### Valves

- Filter elements type SFCT have an internal bypass and anti-drain back diaphragm

F



#### Types SFC-35/36, SFCT-35/36

- Use with Spin-On filter heads SSF-12, SSFT-12 and SSFT-12B
- Connection thread: G3/4
- Operating pressure: SFC: max. 12 bar / 174 PSI  
SFCT: max 7 bar / 100 PSI
- Differential Pressure: SFC: max. 4 bar / 58 PSI  
SFCT: max. 3 bar / 43,5 PSI
- Burst Pressure: SFC: min. 25 bar / 363 PSI  
SFCT: min 21 bar / 305 PSI



#### Type SF-63

- Use with Spin-On filter head SLF
- Connection thread: 3/4–16 UNF
- Operating pressure: max. 14 bar / 200 PSI
- Differential Pressure: max. 5,5 bar / 80 PSI
- Burst Pressure: min. 20 bar / 290 PSI



#### Type SF-67

- Use with Spin-On filter heads SSF-20L/100/120/120L/130/150/160/180 SSF-24B/24N/24S/25B/25FM/25
- Connection thread: 1/2–16 UNF
- Operating pressure: max. 14 bar / 200 PSI
- Differential Pressure: max. 5,5 bar / 80 PSI
- Burst Pressure: min. 20 bar / 290 PSI



#### Types SFC-57/58, SFCT-57/58

- Use with Spin-On filter heads SSF-20L/100/120/120L/130/160 SSF-24B/24N/24S/25B/25FM/25 and SSFT-20B/20
- Connection thread: G1-1/4
- Operating pressure: SFC: max. 12 bar / 174 PSI  
SFCT: max 7 bar / 100 PSI
- Differential Pressure: SFC: max. 4 bar / 58 PSI  
SFCT: max. 3 bar / 43,5 PSI
- Burst Pressure: SFC: min. 25 bar / 363 PSI  
SFCT: min 21 bar / 305 PSI



#### Type SF-65

- Use with Spin-On filter head SAF
- Connection thread: 1–12 UNF
- Operating pressure: max. 14 bar / 200 PSI
- Differential Pressure: max. 5,5 bar / 80 PSI
- Burst Pressure: min. 20 bar / 290 PSI



#### Private Labelling

- On request, the filter elements can be printed with a private label

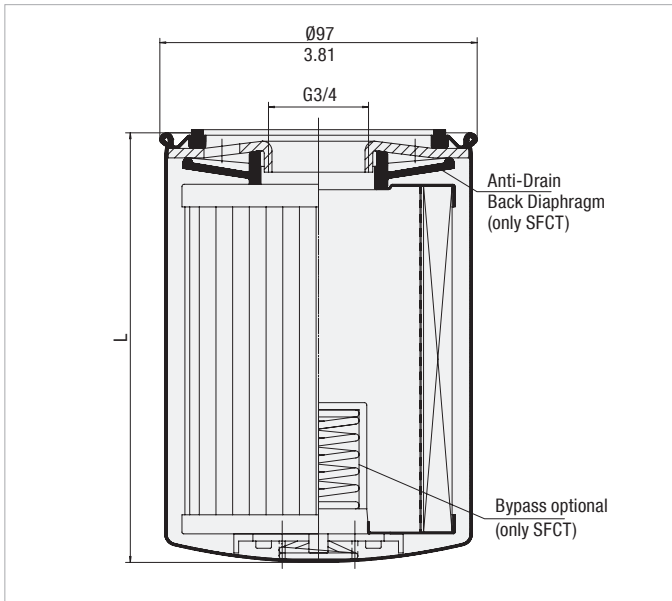

**Spin-On Filter Elements - Type SFC-35 / 36 and SFCT-35 / 36**

Dimensions in mm / in

**Product Description**

STAUFF SFC-35/36 series Spin-On Elements are used with the STAUFF SSF-12 Spin-On Filters with G3/4 threaded ports.

STAUFF SFCT-35/36 series Spin-On Elements have an internal 1,7 bar / 25 PSI bypass and anti-drain back diaphragm for use with STAUFF SSFT-12 and SSFT-12B Tank Top Spin-On Filters.

**Technical Data**
**Connection Thread**

- G3/4

**Operating Pressure**

- Max. 12 bar / 174 PSI

**Burst Pressure**

- Min. 20 bar / 290 PSI

**Temperature Range**

- -30 °C ... +100 °C / -22 °F ... +212 °F

**Seal Contour**

- Type A (see page 151)

**Differential Pressure**

- Paper: Max. 5 bar / 72.5 PSI  
Glass Fibre / Wire Mesh: Max. 10 bar / 145 PSI  
(for any application without bypass valve)

**Bypass Pressure**

- 1,7 bar / 25 PSI (only SFCT-series)

**Media Compatibility**

- Mineral oils, other fluids on request

**Sealing Material**

- NBR (Buna-N®)

**Dimensions**

Order Code	Filter Paper				Inorganic Glass Fibre					
	SFC-3510-E	SFC-3610-E	SFC-3525-E	SFC-3625-E	SFC-3503-AE	SFC-3603-AE	SFC-3510-AE	SFC-3610-AE	SFC-3525-AE	SFC-3625-AE
Element without bypass valve										
Element with bypass valve	SFCT-3510-E	SFCT-3610-E	SFCT-3525-E	SFCT-3625-E			SFCT-3510-AE	SFCT-3610-AE	SFCT-3525-AE	SFCT-3625-AE
Length L (mm/in)	145 5.7	210 8.27	145 5.7	210 8.27	145 5.7	210 8.27	145 5.7	210 8.27	145 5.7	210 8.27
β-Ratio	$\beta_{10} \geq 2$	$\beta_{10} \geq 2$	$\beta_{25} \geq 2$	$\beta_{25} \geq 2$	$\beta_3 \geq 200$	$\beta_3 \geq 200$	$\beta_{10} \geq 200$	$\beta_{10} \geq 200$	$\beta_{25} \geq 200$	$\beta_{25} \geq 200$
Carton Quantity	1	1	1	1	1	1	1	1	1	1
Carton Weight (kg/lbs)	0,9 2	1,3 2,6	0,9 2	1,3 2,6	0,9 2	1,3 2,6	0,9 2	1,3 2,6	0,9 2	1,3 2,6

Order Code	Wire Mesh		Brass Mesh	
	SFC-3560-E	SFC-3660-E	SFC-35125-E	SFC-36125-E
Element without bypass valve				
Element with bypass valve	-	-	-	-
Length L (mm/in)	145 5.7	210 8.27	145 5.7	210 8.27
β-Ratio	n/a	n/a	n/a	n/a
Carton Quantity	1	1	1	1
Carton Weight (kg/lbs)	0,9 2	1,3 2,6	0,9 2	1,3 2,6



Spin-On Elements ▪ Type SFC-57 / 58 and SFCT-57 / 58



Product Description

STAUFF Spin-On Filter Elements of the SFC-/SFCT-57/58 series are used with the STAUFF SSF-20L/100/120/120L/130/160 and SSF-24B/24N/24S/25B/25FM/25 series Spin-On Filters with G1-1/4 threaded ports.

STAUFF SFCT-57/58 series Spin-On Elements have an internal 1,7 bar / 25 PSI bypass and anti-drain back diaphragm for use with STAUFF SSFT-20B/20 Tank Top Spin-On Filters.

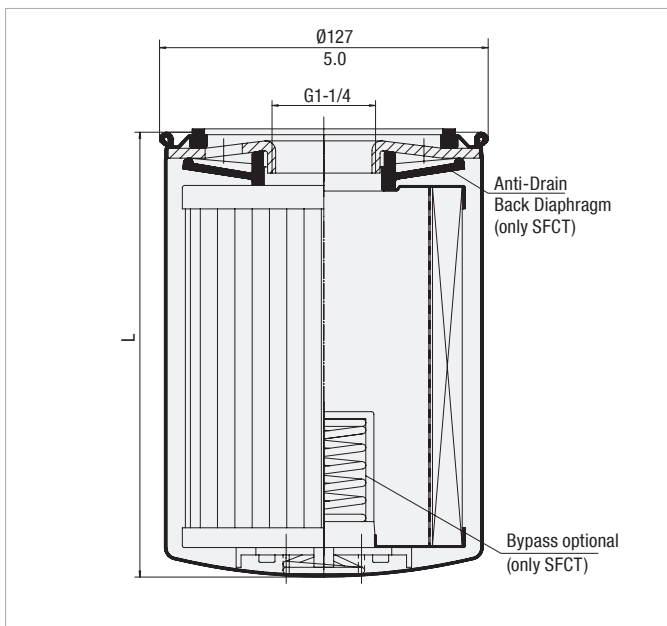

Dimensions in mm / in

F

Technical Data

Connection Thread

- G1-1/4

Operating Pressure

- Max. 12 bar / 174 PSI

Burst Pressure

- Min. 17 bar / 247 PSI

Temperature Range

- -30 °C ...+100 °C / -22 °F ... +212 °F

Seal Contour

- Type A (see page 151)

Differential Pressure

- Paper: Max. 5 bar / 72.5 PSI  
Glass Fibre / Wire Mesh:  
Max. 10 bar / 145 PSI  
(for any application without bypass valve)

Bypass Pressure

- 1,7 bar / 25 PSI  
(only SFCT-series)

Media Compatibility

- Mineral oils, other fluids on request

Sealing Material

- NBR (Buna-N®)

Dimensions

Order Code	Filter Paper				Inorganic Glass Fibre					
	SFC-5710-E	SFC-5810-E	SFC-5725-E	SFC-5825-E	SFC-5703-AE	SFC-5803-AE	SFC-5710-AE	SFC-5810-AE	SFC-5725-AE	SFC-5825-AE
Element without bypass valve										
Element with bypass valve	SFCT-5710-E	SFCT-5810-E	SFCT-5725-E	SFCT-5825-E	-	-	SFCT-5710-AE	SFCT-5810-AE	SFCT-5725-AE	SFCT-5825-AE
Length L (mm/in)	177 6.97	226 8.9	177 6.97	226 8.9	177 6.97	226 8.9	177 6.97	226 8.9	177 6.97	226 8.9
β-Ratio	$\beta_{10} \geq 2$	$\beta_{10} \geq 2$	$\beta_{25} \geq 2$	$\beta_{25} \geq 2$	$\beta_3 \geq 200$	$\beta_3 \geq 200$	$\beta_{10} \geq 200$	$\beta_{10} \geq 200$	$\beta_{25} \geq 200$	$\beta_{25} \geq 200$
Carton Quantity	1	1	1	1	1	1	1	1	1	1
Carton Weight (kg/lbs)	1,4 3	1,85 4	1,4 3	1,85 4	1,4 3	1,85 4	1,4 3	1,85 4	1,4 3	1,85 4

Order Code	Wire Mesh		Brass Mesh	
	SFC-5760-E	SFC-5860-E	SFC-57125-E	SFC-58125-E
Element without bypass valve				
Element with bypass valve	-	-	-	-
Length L (mm/in)	177 6.97	226 8.9	177 6.97	226 8.9
β-Ratio	n/a	n/a	n/a	n/a
Carton Quantity	1	1	1	1
Carton Weight (kg/lbs)	0,9 2	1,3 2,6	0,9 2	1,3 2,6



### Spin-On Elements ■ Type SFC/SFCT-35/36, SFC/SFCT-57/58 and SF-63

The following characteristics are valid for mineral oils with a density of 0,85 kg/dm<sup>3</sup> and the kinematic viscosity of 30 mm<sup>2</sup>/s (30 cSt). The characteristics have been determined in accordance to ISO 3968. SFC-35/36 series Spin-On Elements are used with STAUFF SSF-12 Spin-On Filters, SFCT-35/36 series Spin-On Elements are used with STAUFF SSFT-12 Spin-On Filters, SFC-57/58 series Spin-On Elements are used with STAUFF SSF-20/24/25/100/120/130/160 Spin-On Filters, SFCT-57/58 series Spin-On Elements are used with STAUFF SSFT-20 Spin-On Filters and SF-63 series Spin-On Elements are used with STAUFF SLF-02/03/04 Spin-On Filters.

F

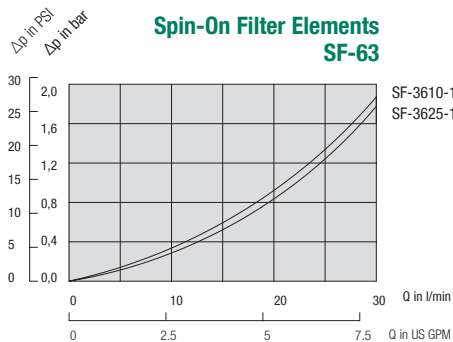
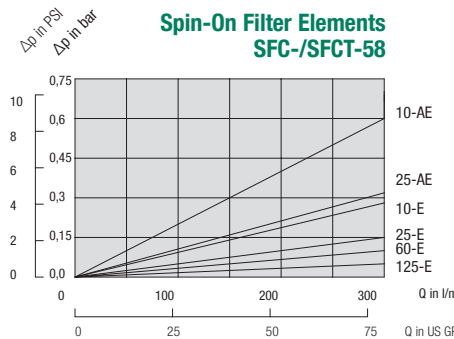
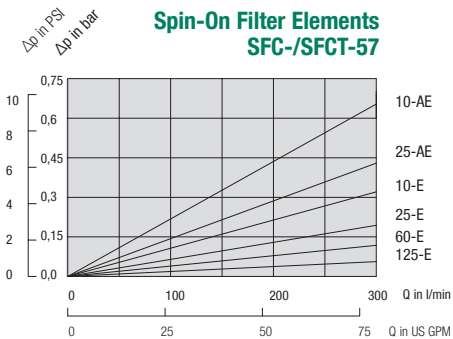
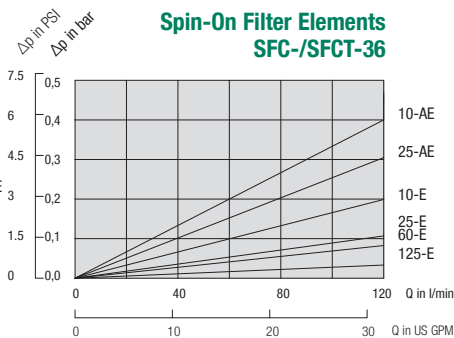
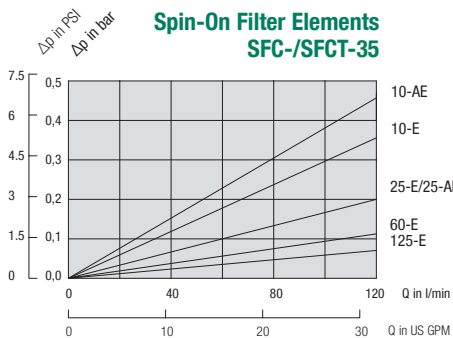

## Clogging Indicators

## Visual Indicators

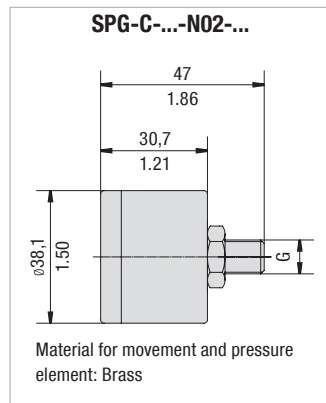
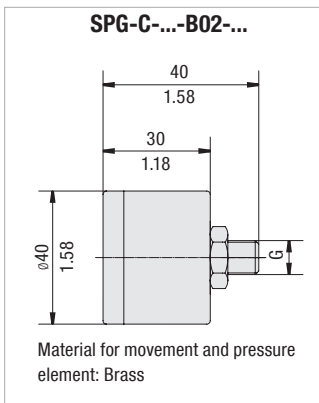

SPG-C-...-B02-...



SPG-C-...-N02-...



SPG-C-...-B02-...



SPG-C-...-N02-...

Visual Pressure Clogging Indicators (for Spin-On Filter in Return-Line applications)						Order Code	
Thread	Connection G	Unit of scale	Range of scale	Coloured Segments			
				Green	Yellow	Red	
BSP	1/8	bar	0 ... 2,5	0 ... 1,2	1,2 ... 1,5	1,5 ... 2,5	SPG-C-040-00002.5-02-P-B02-402923
	1/8	bar	0 ... 4	0 ... 2,5	2,5 ... 3	3 ... 4	SPG-C-040-00004-02-P-B02-402922
	1/8	bar	0 ... 12	without coloured segments			SPG-C-040-00012-02-P-B02
NPT	1/8	PSI	0 ... 100	0 ... 13	13 ... 15	15 ... 100	SPG-C-040-00100-03-P-N02-402927
	1/8	PSI	0 ... 100	0 ... 21	21 ... 25	25 ... 100	SPG-C-040-00100-03-P-N02-402928
Visual Vacuum Clogging Indicators (for Spin-On Filter in Suction-Line applications)						Order Code	
BSP	1/8	cm Hg	-76 ... 0	-13 ... 0	-18 ... -13	-76 ... -18	SPG-C-040-(-76)-00000-22-P-B02-402924
	1/8	in Hg	-30 ... 0	-4 ... 0	-6 ... -4	-30 ... -6	SPG-C-040-(-30)-00000-23-P-N02-402925
NPT	1/8	in Hg	-30 ... 0	-9 ... 0	-11 ... -9	-30 ... -11	SPG-C-040-(-30)-00000-23-P-N02-402926

## Electrical Clogging Switch

## Order Code

**Limit-Switch - G42NO - S - G02 - B1.3**

①

②

③

④

⑤

## ① Type

Limit-Switch

## ② Connector Type

Electrical Clogging Switch 42 V, NO	<b>G42NO</b>
Electrical Clogging Switch 42 V, NC	<b>G42NC</b>
Electrical Clogging Switch 110 V ... 230 V, two-way contact (only for Plug Type W)	<b>G230</b>

## ③ Plug Type

M12 Five-Pin Connector according to IEC 61076-2-101	<b>M12</b>
AMP-Junior-Timer Plug	<b>A</b>
DEUTSCH Plug DT04-2P	<b>D</b>
Rubber boot	<b>S</b>
90 degree Polyamide cap (only for Connector Type G230)	<b>W</b>

## ④ Thread Type

1/8 BSP	<b>G02</b>
1/8 NPT	<b>N02</b>

## ⑤ Pressure Setting

1,3 bar / 18.8 PSI	<b>B1.3</b>
-0,1 bar / -1.45 PSI*	<b>B-0.1</b>

\* (only for Plug Type W and Connector Type G230)

## Dimensions Plug Type

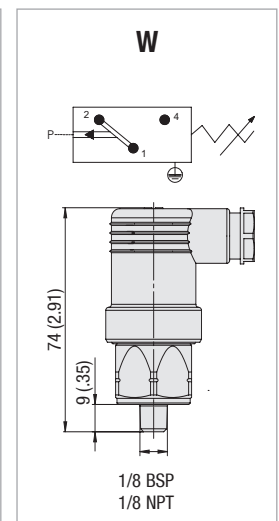
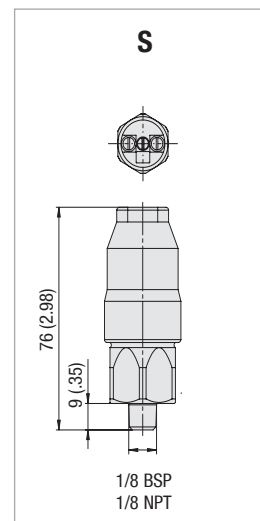
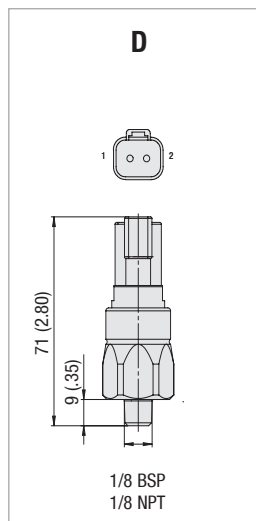
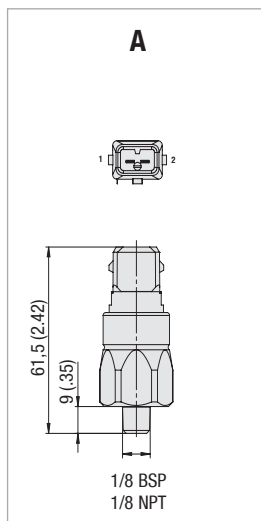
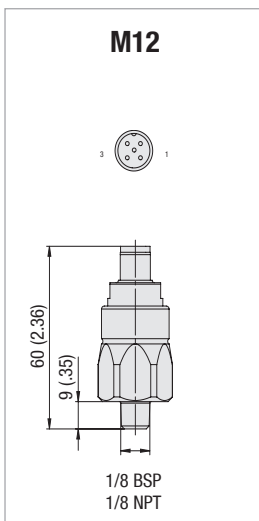

Note: The customer / user carries the responsibility for the electrical connection.

Dimensional drawings: All dimensions in mm/in.

